

The #2160 Passage Mechanism.

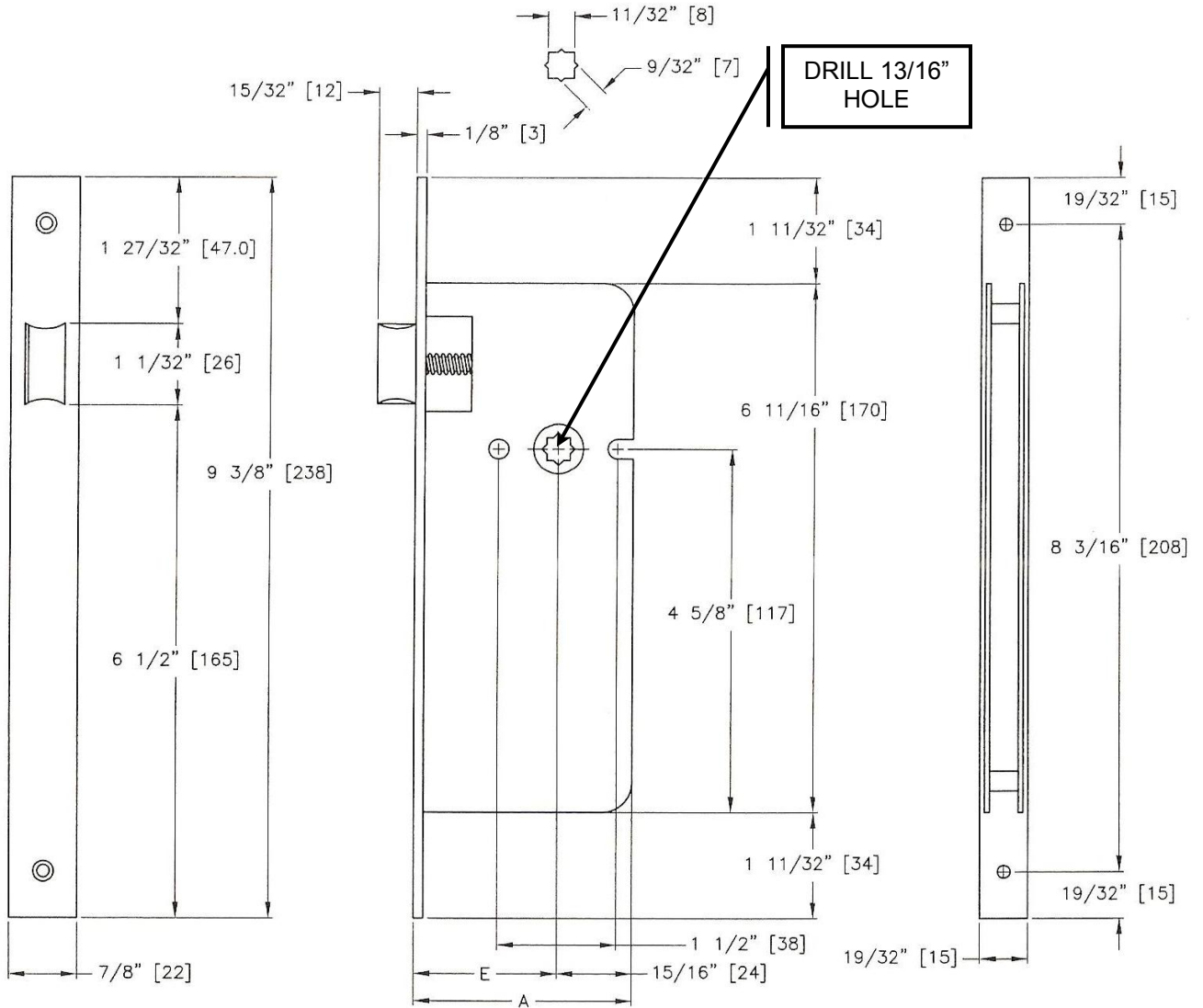

DRILL $13/16$ " HOLE

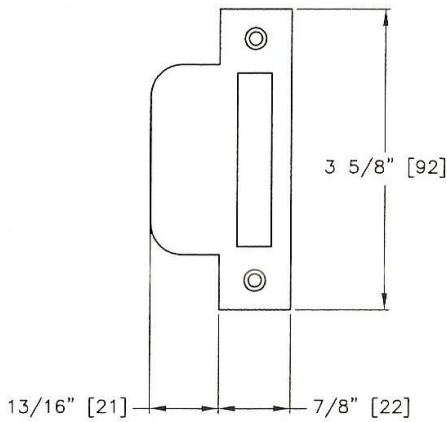

Strike for #2160 Mechanism
Part number 356

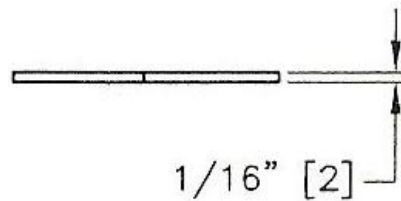

Inches [mm]

	$1-9/16$ [40]	$1-3/4$ [45]	$1-31/32$ [50]	$2-3/8$ [60]	$2-3/4$ [70]	$3-5/32$ [80]
<i>E = Backset</i>						
<i>A = E + [24]</i>	$2-1/2$ [64]	$2-23/32$ [69]	$2-29/32$ [74]	$3-5/16$ [84]	$3-11/16$ [94]	$4-3/32$ [104]