

The #2160 Passage Mechanism.

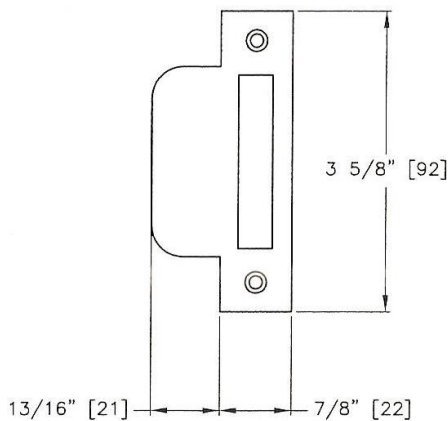

Strike for #2160 Mechanism Part number 356

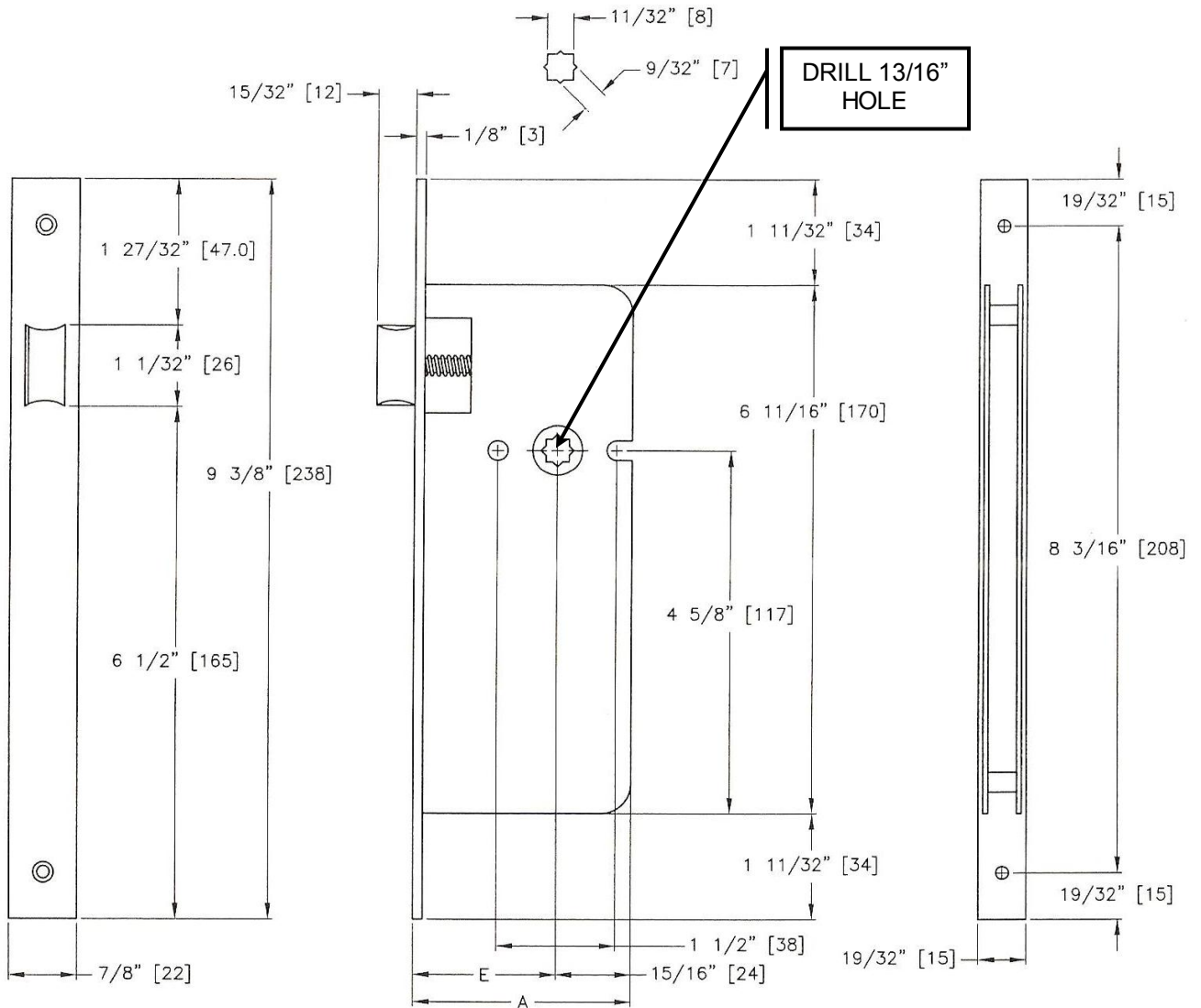
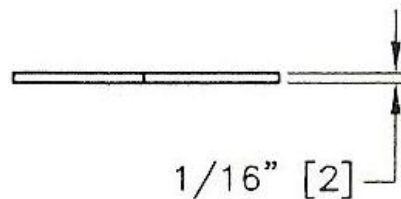

	Inches [mm]					
$E = \text{Backset}$	$1 \frac{9}{16}$ [40]	$1 \frac{3}{4}$ [45]	$1 \frac{31}{32}$ [50]	$2 \frac{3}{8}$ [60]	$2 \frac{3}{4}$ [70]	$3 \frac{5}{32}$ [80]
$A = E + [24]$	$2 \frac{1}{2}$ [64]	$2 \frac{23}{32}$ [69]	$2 \frac{29}{32}$ [74]	$3 \frac{5}{16}$ [84]	$3 \frac{11}{16}$ [94]	$4 \frac{3}{32}$ [104]